

The **Petkus MP200** is a precision laboratory grade machine that meets all the requirements of a hemp seed cleaning machine, performing all functions, including stick and stem removal, based on a maximal capacity of 200 kg/h.

Function:

The uncleaned seed material is fed by a vibrator bottom or optional rotating feed drum into the machine. The material flows into the screen compartment where the light material (leaf, flower and dust) is separated by a pre-aspiration channel. The built in fan provides a large air volume for suction in the vertical primary aspiration section. Large particles such as stems and bud balls are separated by the upper screen and small debris and broken seed are separated by the lower screen. After the screen separation process, the material flows into the indented cylinder. Good hemp seed is separated from the difficult to remove, small sticks and stems in the indented cylinder. This produces very clean seed in one pass through a single machine.

Advantages:

- Easy and quick changing of the screens and indented cylinder for different size seeds and varieties
- Identical size upper and lower screens – interchangeable
- Upper and lower screens cleaned by an electrical vibration unit
- All grading operations are clearly visible when the machine is in operation and can be adjusted quickly and easily if required.
- The machine is self emptying within a very short period of time.

Construction:

- Pre-aspiration channel
- 3 screen fractions (upper and lower –sorting screens)
- Screens cleaning by rubber balls
- Interchangeable screen segments stored in the support table
- Adjustable Indented cylinder operation
- included Cyclone for air filter operation

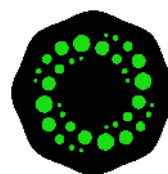

HPP
HEMP PROCESSING PARTNERS

www.hempprocessingpartners.com
(970) 707-3030

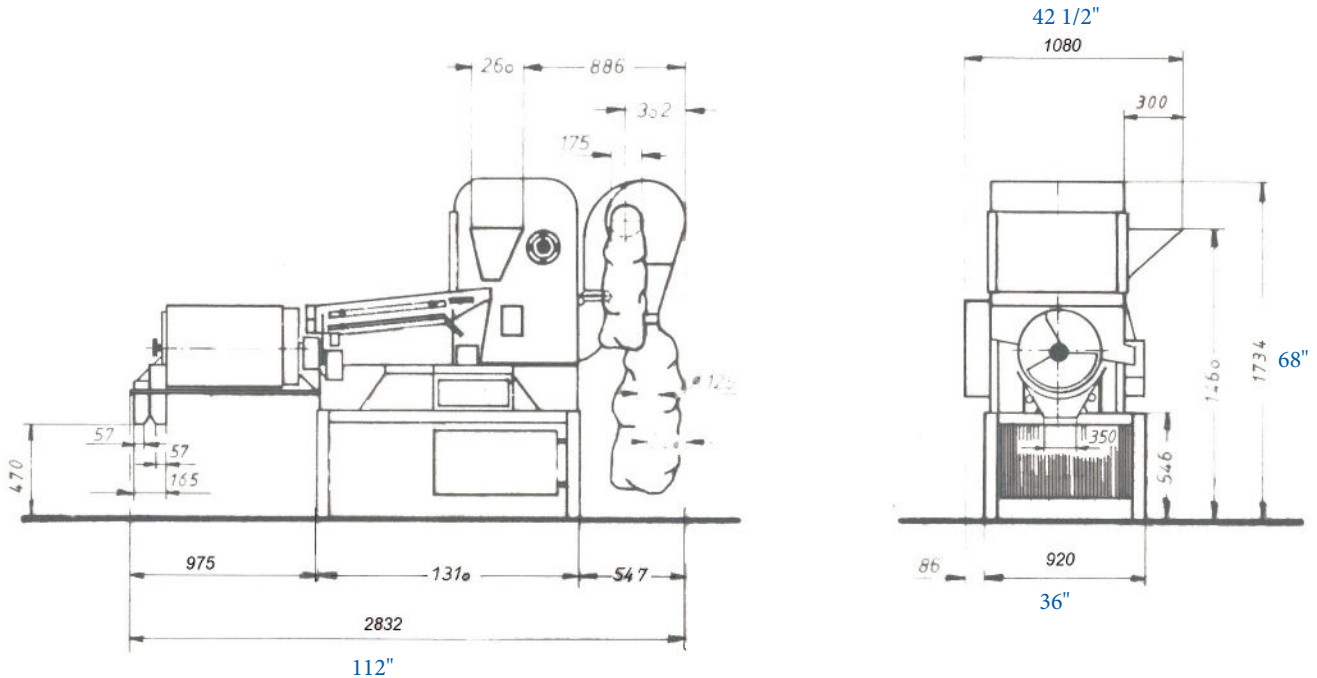

Technical Data		MP 200	
Capacity			
Seed cleaning	kg/h	200	
Upper sieve	pc.	1	
Lower sieve	pc.	1	
Screen area	m ²	0,37	
Indented cylinder	pc.	1	
	Length	mm	325
	Diameter	mm	375
	Working area	m ²	0,35
Drive-Motor	kW	2,2	
Inbuilt fan, 140 Pa	U/min	1450	
	Air Volume	m ³ /min	40
Dimension (with support table)			
	Length	mm	2880
	Width	mm	1050
	Height	mm	1210-1760
	Weight, approx.	kg	170-220
Basic working space requirement	m ²	1,5	

Technical Alteration reserved.